

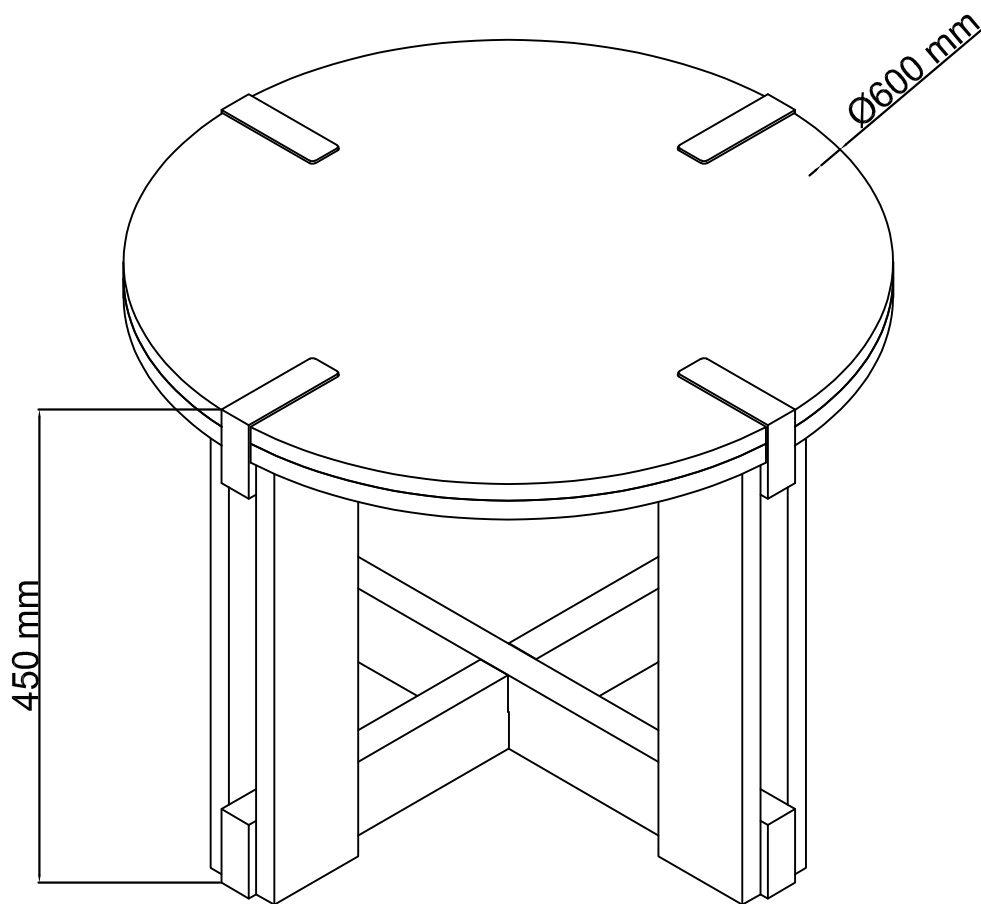

ASSEMBLY INSTRUCTION

JARON ROUND LAMP TABLE

ITEM CODE - 85597





Imported by Amart Furniture Pty Ltd, Qld, Brisbane Australia.
for any assistance to assembly or for missing parts please phone
Amart Furniture, Customer Service Freecall 1800 351 084

PRE-ASSEMBLY PREPARATION

BEFORE YOU START :

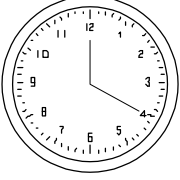

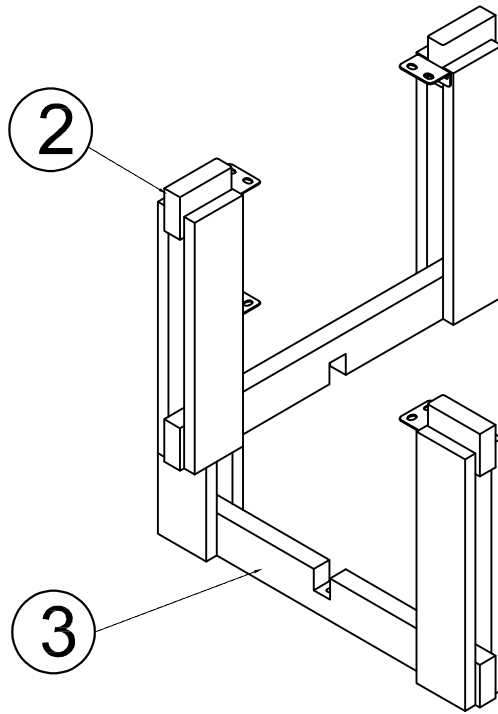
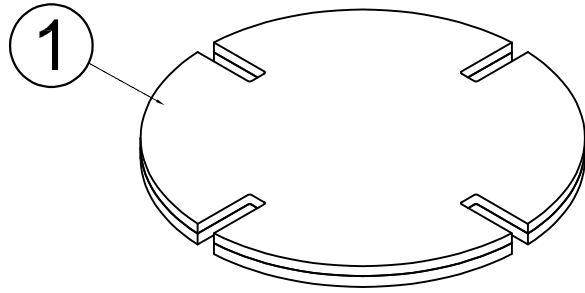

1. Choose a clean, level, spacious assembly area. Avoid hard surfaces that may damage the product
2. Take care when lifting. Product should be assembled as near as possible to the point of use
3. Ensure that you have all required contents for complete assembly
4. Always read the assembly instructions carefully before beginning assembly.
5. Keep all hardware parts and packaging out of reach of small children.
6. Do not over tighten the screws and bolts as this may damage the threads

	
ALLOW 20 MINUTES	2 PEOPLE REQUIRED
ADDITIONAL TOOLS REQUIRED	

PARTS LIST







1	TOP	1 PC	2	TOP PEDESTAL	1 PC
3	BOTTOM PEDESTAL	1 PC			

A BOLTS  M6x25: 8 pcs	B BOLTS  M6x40: 1 pc	C FLAT WASHER  M6x2x19: 9 pcs	D SPRING WASHER  M6x1.2x10: 9 pcs	E KEY  M4x60: 1 pc
---	--	---	--	--

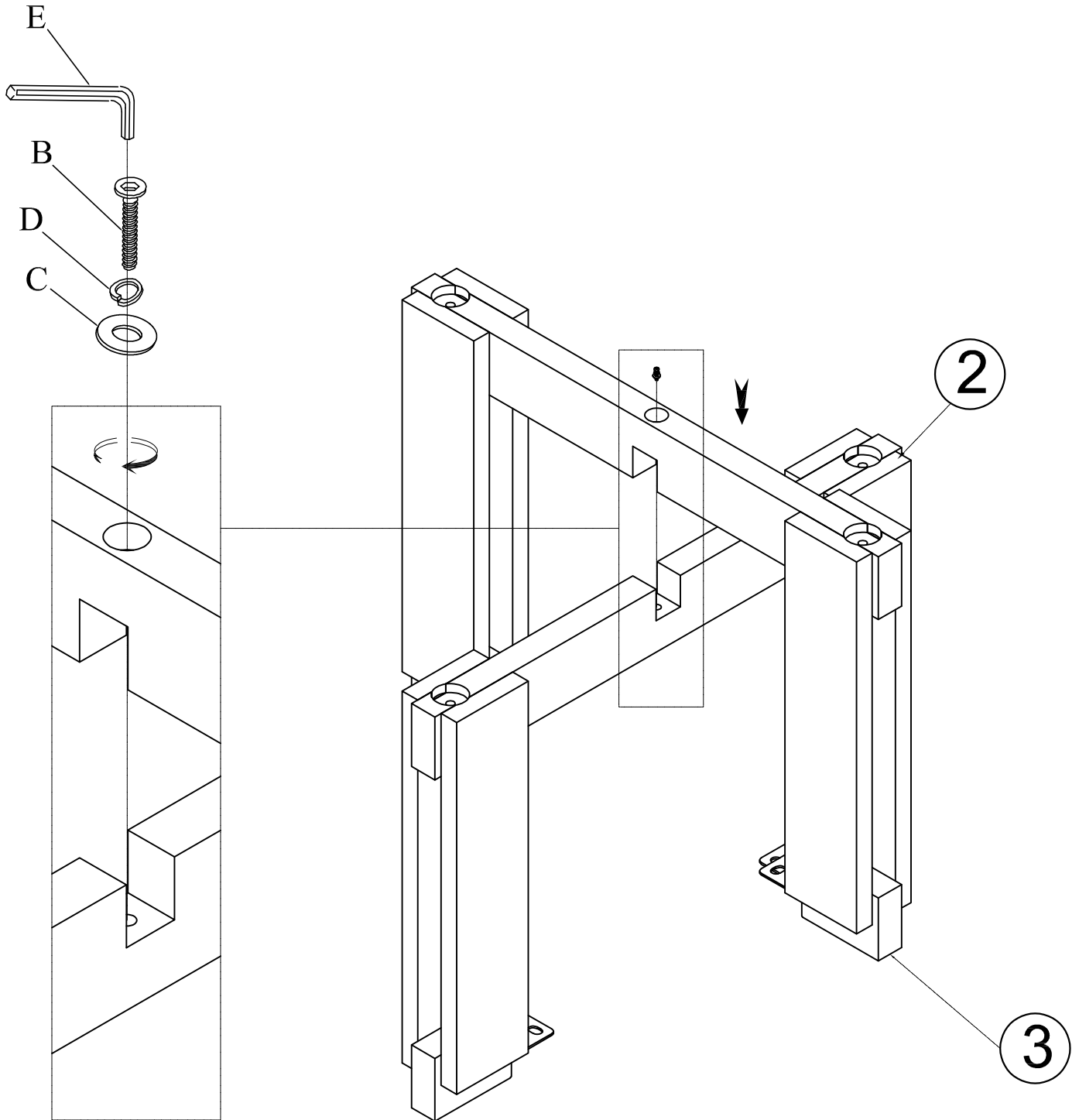
Step 1 :

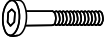
- Attach the Bottom Pedestal (3) to the Top Pedestal (2). Using Bolts (B), Spring Washer (D), Flat Washer (C) and tighten with Allen Key (E).





B BOLTS  M6x40: 1 pc	C FLAT WASHER  M6x2x19: 1 pc	D SPRING WASHER  M6x1.2x10: 1 pc	E KEY  M4x60: 1 pc
--	--	--	---

Step 2 :

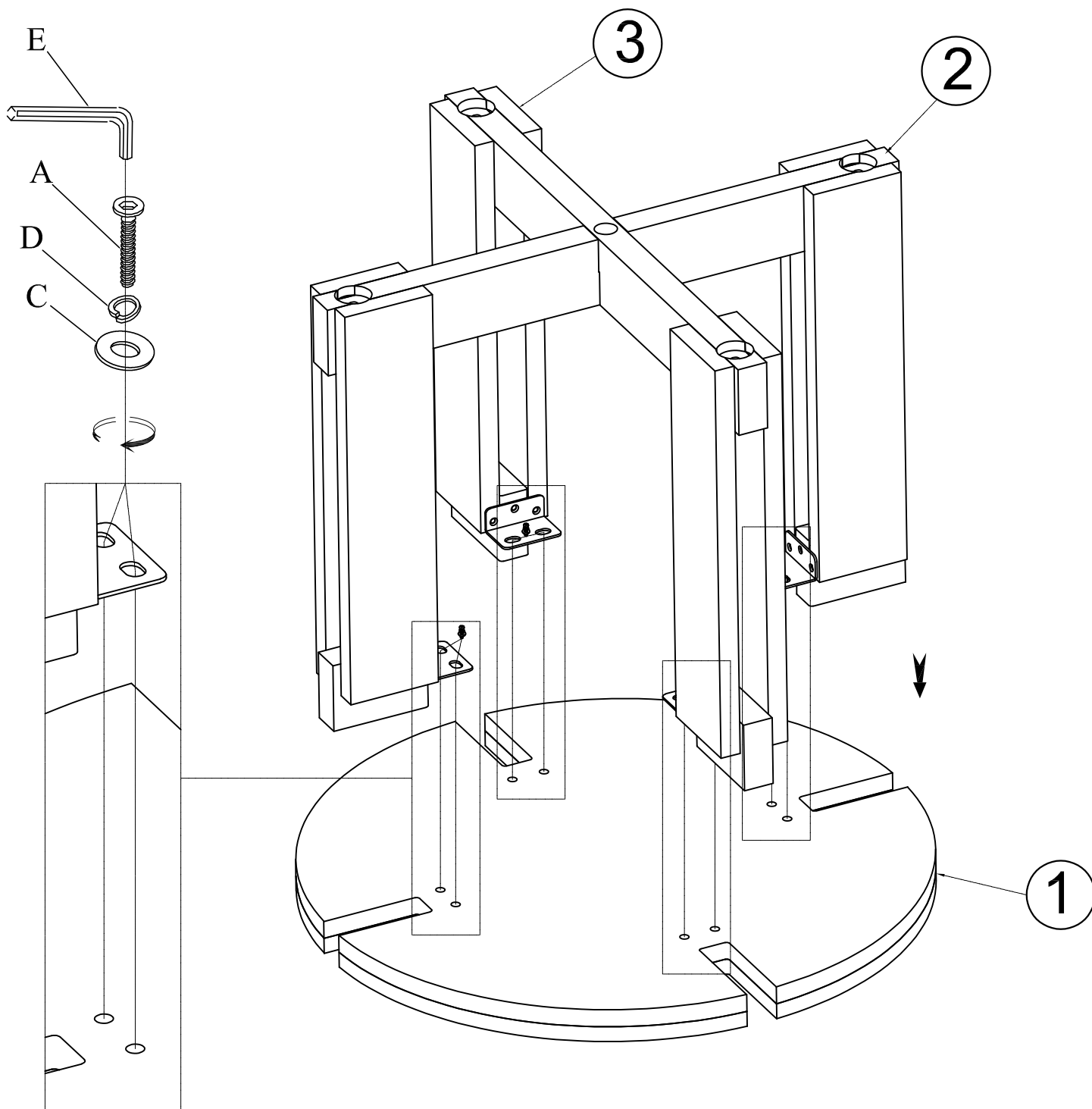
- Attach the Bottom Pedestal (3), Top Pedestal (2) to the Top (1). Using Bolts (A), Spring Washer (D), Flat Washer (C) and tighten with Allen Key (E).

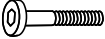

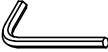
A BOLTS	C FLAT WASHER	D SPRING WASHER	E KEY
			
M6x25: 8 pcs	M6x2x19: 8 pcs	M6x1.2x10: 8 pcs	M4x60: 1 pc

ASSEMBLY COMPLETE

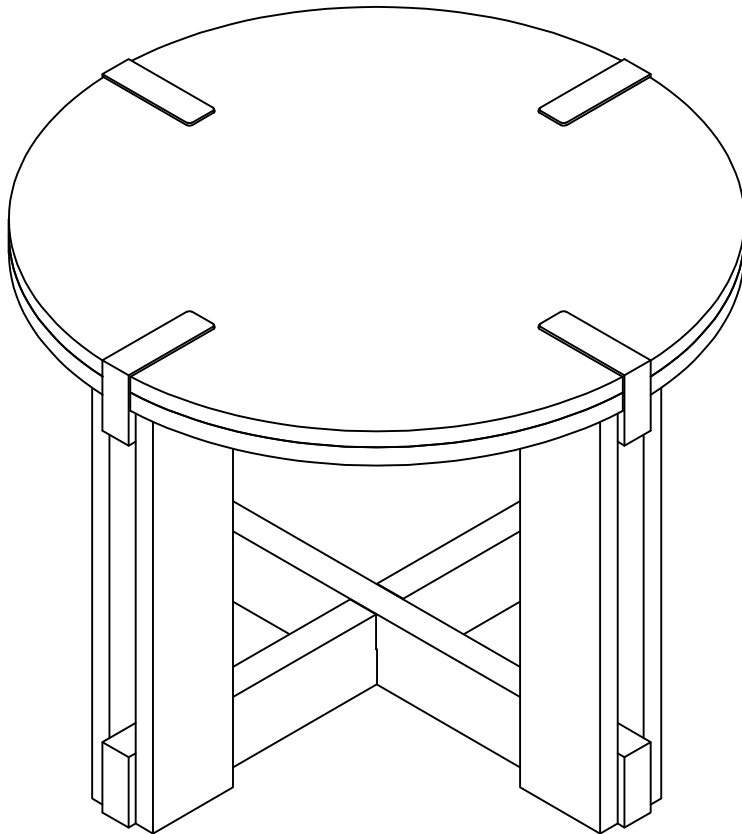

DO NOT PUSH OR DRAG THIS TABLE - by doing so, it may cause damage to the legs.

DO NOT SIT OR LEAN ON THE EDGE OF THE TABLE - this may cause the table to tip to one side.

Product Care:

As your timber is supplied from sustainable forests there will be natural variations in surface texture and grain like knots, mineral streaks and sap runs that may affect the finish. These differences in character are not defects, but distinctions that make each piece of furniture unique. Our furniture is built to last. Following these steps for basic care should protect your investment for years to come.

- Dust frequently with a clean damp lint-free cloth. This will help remove abrasive build up which can damage a finish over time.
- Do not place hot objects on any furniture surface. Always use a hot plate or placemat. Laminate and lacquer finishes on table tops provide added scratch and heat resistance to our furniture, but they can still be damaged without proper care.
- Avoid exposing your furniture to strong sunlight, heat outlet, open windows or dampness. Prolonged exposure to direct sunlight can fade the finish of your furniture, while extreme temperature and humidity changes can cause cracking or splitting.
- Do not expose your furniture to any liquids. Never allow water to sit on your furniture. Alcohol, nail polish and perfume are also dangerous as they will dissolve the lacquer finish on contact and may require professional repairs.
- Do not allow plastic to come in direct contact with your furniture. Chemicals in the plastic of placemats etc may soften and mark the finish if left in contact with the furniture for a period of time.